

Steel finish



Icon finish

## Modular electric deck oven 2 decks composition

serieS is the most advanced and customizable oven in the world, ideal for **perfect baking of pizza, bakery, pastry, and gastronomy.**

Customize serieS choosing dimensions, number, and type of baking chamber, **material** for baking surface (refractory deck, or embossed steel deck), door opening, Steel or Icon finish, and so much more. serieS meets all production needs thanks to specific and integrable baking chambers: **Multi**bake, **Roman**bake, **Stone**bake, **Pastry**bake, **Steamb**bake and **Fast**bake. Power consumption reduced by 35% and baking speed increased by 20% are the features that make serieS the evolution of baking; the professional oven for those who want to extend their business with a single tool



### OPERATION

- Heated by highly performing armoured heating elements or spiral heating (stonebake)
- Temperature management using P.I.D. permit the automatic energy regulation to the quantity of the baked product Adaptive-Power® Technology
- Separated temperature management of ceiling and floor Dual-Temp® Technology
- Separated power management of ceiling and floor Dual-Power® Technology
- Automatic cleaning program for carbonization
- Maximum temperature reached 450°C
- Continuous temperatures monitoring in baking chamber by 2 thermocouples
- Vapour ducting using manual butterfly valve

### CONSTRUCTION

- Structure made in folded stainless steel
- Side panels in painted sheet metal
- Channel hood
- Steam duct in stainless steel plate
- Stainless steel door, panoramic glass element, door handle in stainless steel
- Aluminated steel top and side structure
- Refractory brick baking surface
- Double LED light
- Rock wool heat insulation

### ACCESSORIES

- Leavening prover on wheels height 600, 800mm
- Stand with wheels height 400, 600, 800, 950, 1050mm
- Leavening with humidifier 250W
- Spacer element height 300mm
- Refractory brick or buckle plate surface
- Additional tray holder guides for compartment and stand
- Motor for hood vapours extraction 500 m3/h
- Max power optimizer (Fource®/Fource+®Technology)
- Door opening from bottom to top
- Lateral tool-holder for compartment
- Oversized hood, frontless hood H=175mm
- Remote-Master® Technology
- Kit support feet for countertop installation H=15mm
- Gasket kit for door with standard opening

### INTERNAL BAKING DIMENSIONS

Internal height	160-220mm
Internal depth	735mm
Internal width	475mm
Baking surface	0,35m <sup>2</sup>

### STANDARD EQUIPMENT

- Color multilanguage display TFT 5"
- 100 customized programs with baking steps
- Eco-Standby BY™ Technology for break
- Power-Booster™ Technology for workload peaks
- Half-Load™ Technology for partial load
- Front and rear power balance Delta-Power™ Technology
- Customized Hotkey with recurring control
- Self-diagnosis with error message display
- Independent double baking Timer and Multitimer
- Weekly Timer with the possibility to program two lightings and two power off every day
- Independent security device of maximum temperature
- USB input and WiFi module for sw update
- SmartBaking app

### TOP VIEW

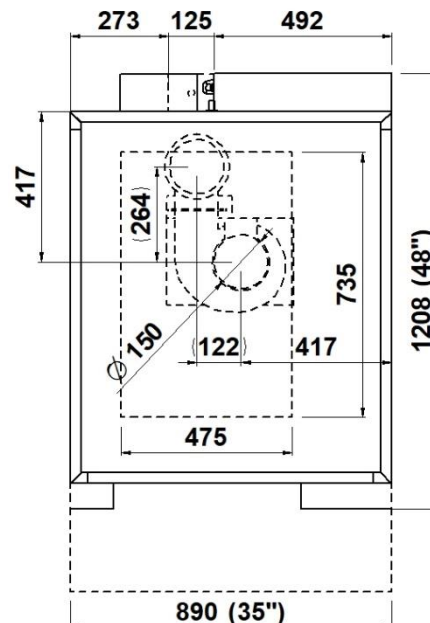

**1 baking chamber height 16cm (with FASTBAKE 15cm)**

(assembled with stand height 950mm)

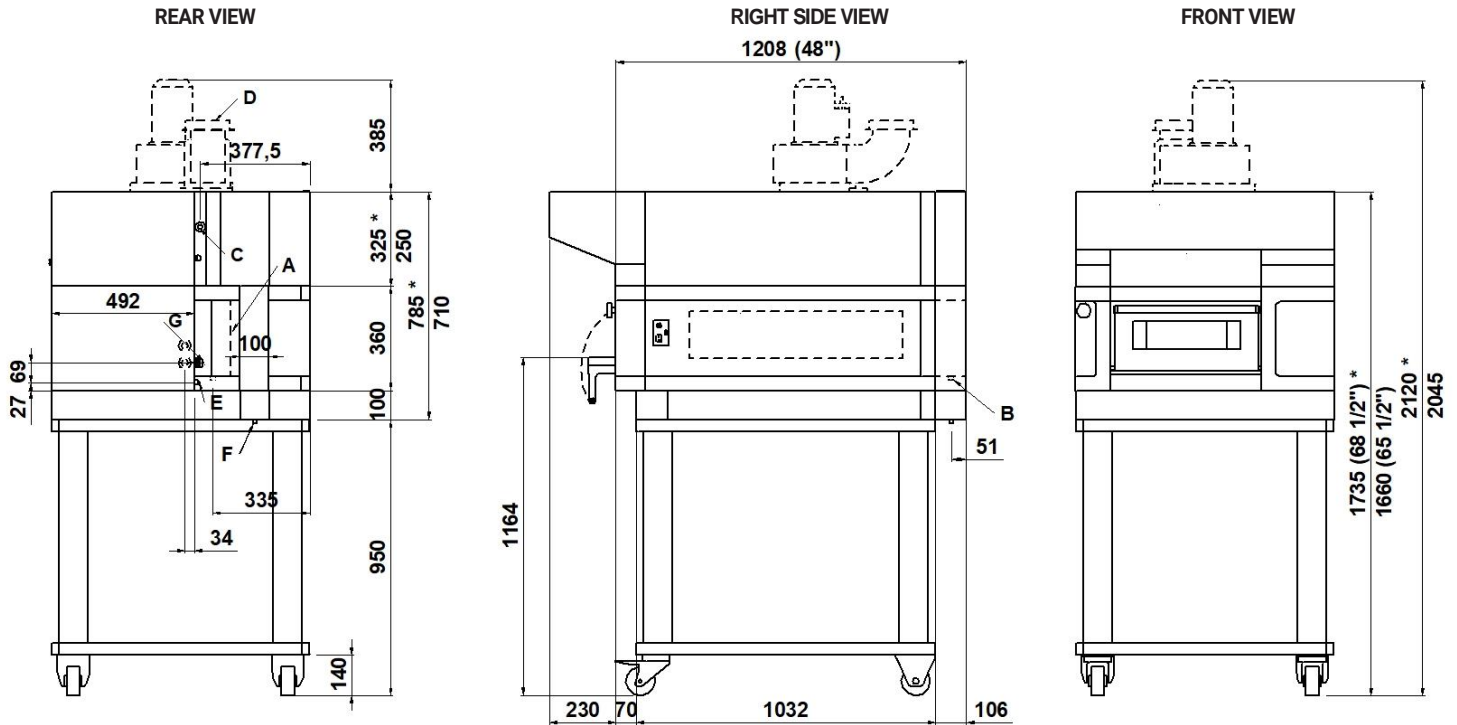

**NOTE:** The dimensions indicated in the views are in millimeters. \*Dimensions refer to the oversized hood.

<b>A</b> steamer 1200W (see data sheet)	<b>B</b> 3/4" male steamer water inlet	<b>C</b> Ø16 Hood condensate exhaust	<b>D</b> Ø150 steam exhaust
<b>E</b> M6 equipotential screws	<b>F</b> Ø12 condensate exhaust	<b>G</b> fairleads	

**DIMENSIONS**

External height	460mm
External depth	1208mm
External width	890mm
Weight	160kg

**SHIPPING INFORMATION**

Packed in wooden crate	
Height	860mm
Depth	1643mm
Width	1100mm
Weight	(160+50)kg

**FEEDING AND POWER**

Standard feeding	
A.C. V400 3N	
Feeding on request	
A.C. V230 3	
Frequency	50/60Hz
Max power	5,1kW
*Average power cons	1,5kWh
Connecting cable for each chamber	
type H07RN-F	
5x2,5mm <sup>2</sup> (V400 3N)	
4x4mm <sup>2</sup> (V230 3)	
Power supply (optional prover)	
A.C. V230 1N 50/60 Hz	
Max power	1.5kW
*Average power cons	0.8kWh
Conn. Cable type H07RN-F	3x1,5mm <sup>2</sup>

**TOTAL BAKING CAPACITY**

Tray (600x400)mm	1	When combined with leavening	
Pizza diameter 300mm	2	compartment or stand:	
Pizza diameter 450mm	1	Max height	1940mm
		Max weight	(225+60)kg

\* This value is subject to variation according to the way in which the equipment is used

**NOTE:** MORETTI FORNI S.P.A. reserves the right to modify the characteristics of the products illustrated in this publication without prior notice

**2 baking chambers height 16cm (with FASTBAKE 15cm)**  
(assembled with prover height 800mm)

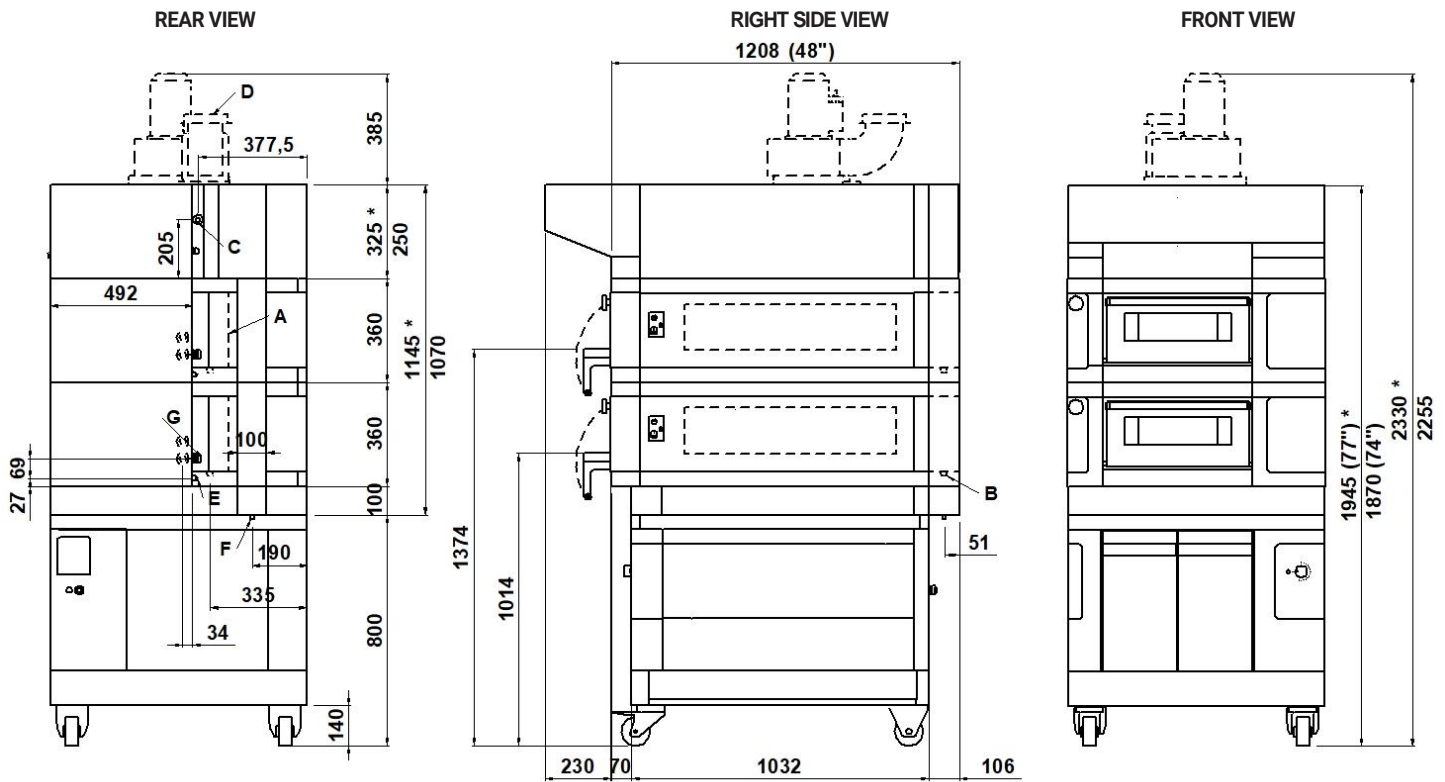

**NOTE:** The dimensions indicated in the views are in millimeters. \*Dimensions refer to the oversized hood.

<b>A</b> steamer 1200W (see data sheet)	<b>B</b> 3/4" male steamer water inlet	<b>C</b> Ø16 Hood condensate exhaust	<b>D</b> Ø150 steam exhaust
<b>E</b> M6 equipotential screws	<b>F</b> Ø12 condensate exhaust	<b>G</b> fairleads	

**DIMENSIONS**

External height	820mm
External depth	1208mm
External width	890mm
Weight	270kg

**SHIPPING INFORMATION**

Packed in wooden crate	
Height	1220mm
Depth	1643mm
Width	1100mm
Weight	(270+60)kg

**FEEDING AND POWER**

Standard feeding	
A.C. V400 3N	
Feeding on request	
A.C. V230 3	
Frequency	50/60Hz
Max power	10,2kW
*Average power cons	3,0kWh
Connecting cable for each chamber	
type H07RN-F	
5x2,5mm <sup>2</sup> (V400 3N)	
4x4mm <sup>2</sup> (V230 3)	
Power supply (optional prover)	
A.C. V230 1N 50/60 Hz	
Max power	1.5kW
*Average power cons	0.8kWh
Conn. Cable type H07RN-F	3x1,5mm <sup>2</sup>

**TOTAL BAKING CAPACITY**

Tray (600x400)mm	2	When combined with leavening compartment or stand:	
Pizza diameter 300mm	4	Max height	2150mm
Pizza diameter 450mm	2	Max weight	(335+70)kg

\* This value is subject to variation according to the way in which the equipment is used

**NOTE:** MORETTI FORNI S.P.A. reserves the right to modify the characteristics of the products illustrated in this publication without prior notice

**3 baking chambers height 16cm (with FASTBAKE 15cm)**  
(assembled with prover height 600mm)

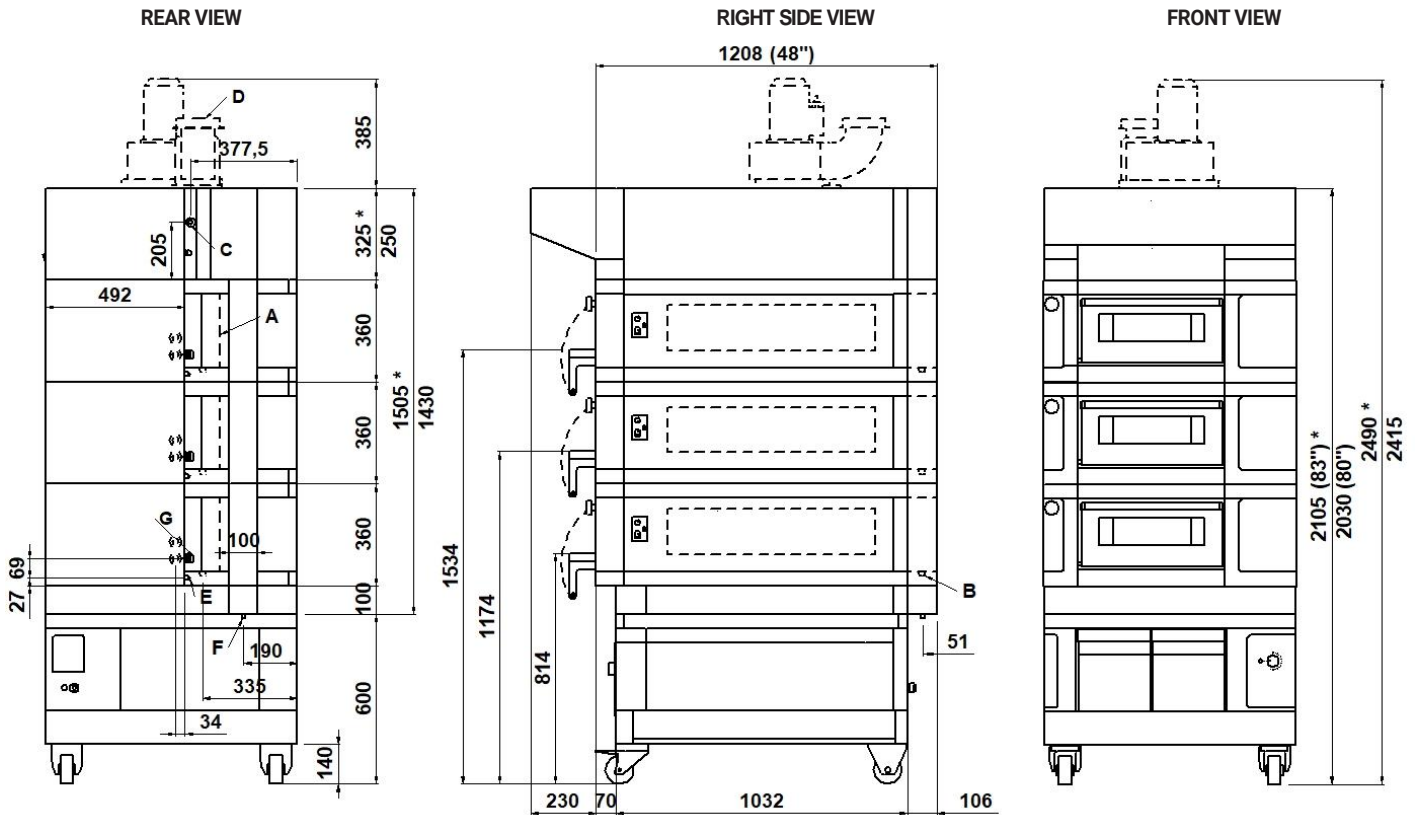

**NOTE:** The dimensions indicated in the views are in millimeters. \*Dimensions refer to the oversized hood.

<b>A</b> steamer 1200W (see data sheet)	<b>B</b> 3/4" male steamer water inlet	<b>C</b> Ø16 Hood condensate exhaust	<b>D</b> Ø150 steam exhaust
<b>E</b> M6 equipotential screws	<b>F</b> Ø12 condensate exhaust	<b>G</b> fairleads	

**DIMENSIONS**

External height	1180mm
External depth	1208mm
External width	890mm
Weight	380kg

**SHIPPING INFORMATION**

Packed in wooden crate	
Height	1580mm
Depth	1643mm
Width	1100mm
Weight	(380+70)kg

**FEEDING AND POWER**

Standard feeding	
A.C. V400 3N	
Feeding on request	
A.C. V230 3	
Frequency	50/60Hz
Max power	15,3kW
*Average power cons	4,5kWh
Connecting cable for each chamber	
type H07RN-F	
5x2,5mm <sup>2</sup> (V400 3N)	
4x4mm <sup>2</sup> (V230 3)	
Power supply (optional prover)	
A.C. V230 1N 50/60 Hz	
Max power	1.5kW
*Average power cons	0.8kWh
Conn. Cable type H07RN-F 3x1,5mm <sup>2</sup>	

**TOTAL BAKING CAPACITY**

Tray (600x400)mm	3	When combined with leavening compartment or Stand:	
Pizza diameter 300mm	6	Max height	2310mm
Pizza diameter 450mm	3	Max weight	(445+80)kg

\* This value is subject to variation according to the way in which the equipment is used

**NOTE:** MORETTI FORNI S.P.A. reserves the right to modify the characteristics of the products illustrated in this publication without prior notice

**2 baking chambers height 16+22 cm (with FASTBAKE 15+22 cm)**  
(assembled with prover height 800mm)

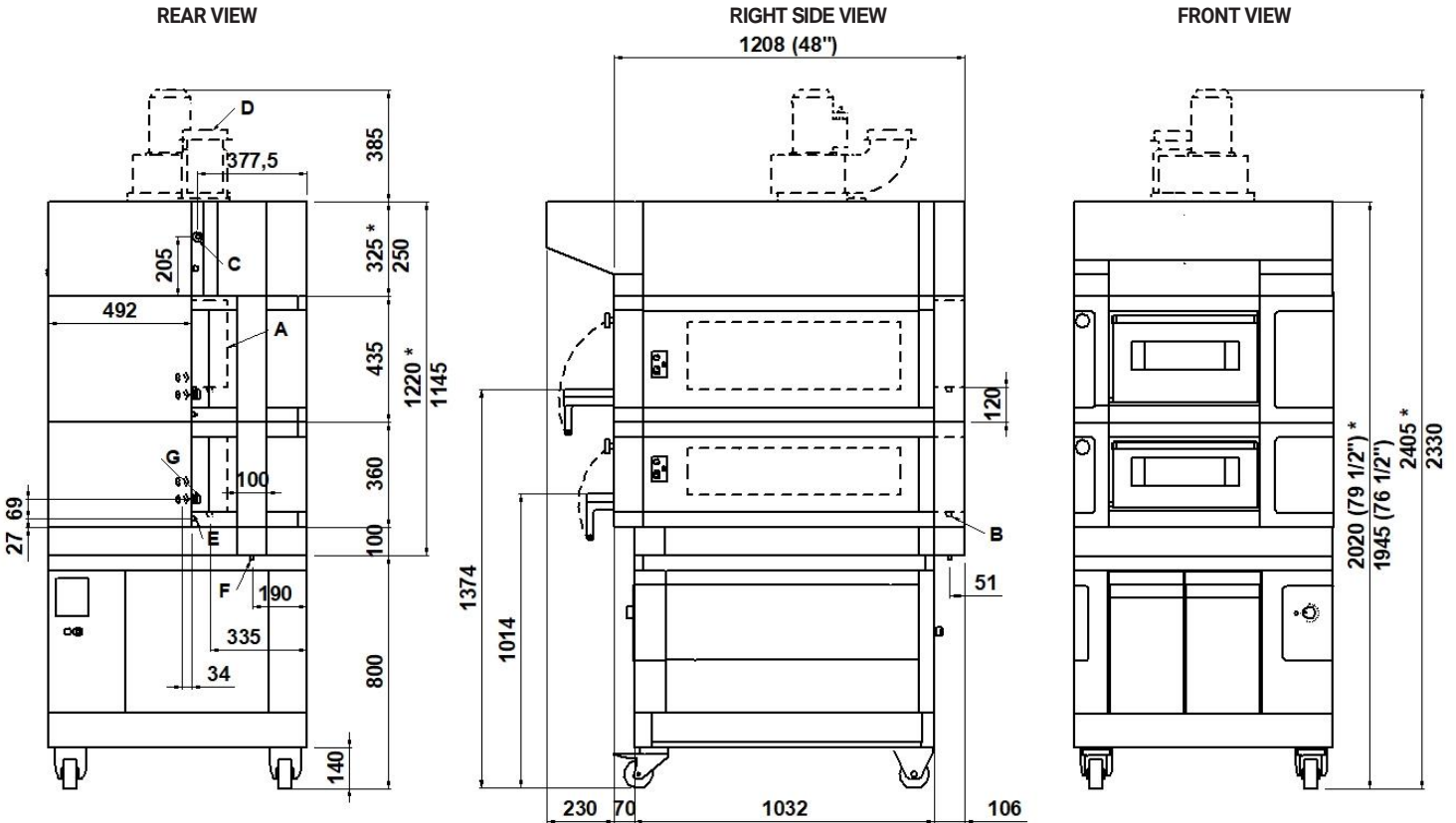

**NOTE:** The dimensions indicated in the views are in millimeters. \*Dimensions refer to the oversized hood.

<b>A</b> steamer 1200W (see data sheet)	<b>B</b> 3/4" male steamer water inlet	<b>C</b> Ø16 Hood condensate exhaust	<b>D</b> Ø150 steam exhaust
<b>E</b> M6 equipotential screws	<b>F</b> Ø12 condensate exhaust	<b>G</b> fairleads	

**DIMENSIONS**

External height	895mm
External depth	1208mm
External width	890mm
Weight	285kg

**SHIPPING INFORMATION**

Packed in wooden crate	
Height	1300mm
Depth	1643mm
Width	1100mm
Weight	(285+60)kg

**FEEDING AND POWER**

Standard feeding	
A.C. V400 3N	
Feeding on request	
A.C. V230 3	
Frequency	50/60Hz
Max power	10,2kW
*Average power cons	3,0kWh
Connecting cable for each chamber	
type H07RN-F	
5x2,5mm <sup>2</sup> (V400 3N)	
4x4mm <sup>2</sup> (V230 3)	
Power supply (optional prover)	
A.C. V230 1N 50/60 Hz	
Max power	1.5kW
*Average power cons	0.8kWh
Conn. Cable type H07RN-F 3x1,5mm <sup>2</sup>	

**TOTAL BAKING CAPACITY**

Tray (600x400)mm	2	When combined with leavening compartment or stand:	
Pizza diameter 300mm	4	Max height	2230mm
Pizza diameter 450mm	2	Max weight	(355+70)kg

\* This value is subject to variation according to the way in which the equipment is used  
**NOTE:** MORETTI FORNI S.P.A. reserves the right to modify the characteristics of the products illustrated in this publication without prior notice

**3 baking chambers height 16+16+22 cm (with FASTBAKE 15+15+22 cm)**  
(assembled with prover height 600mm)

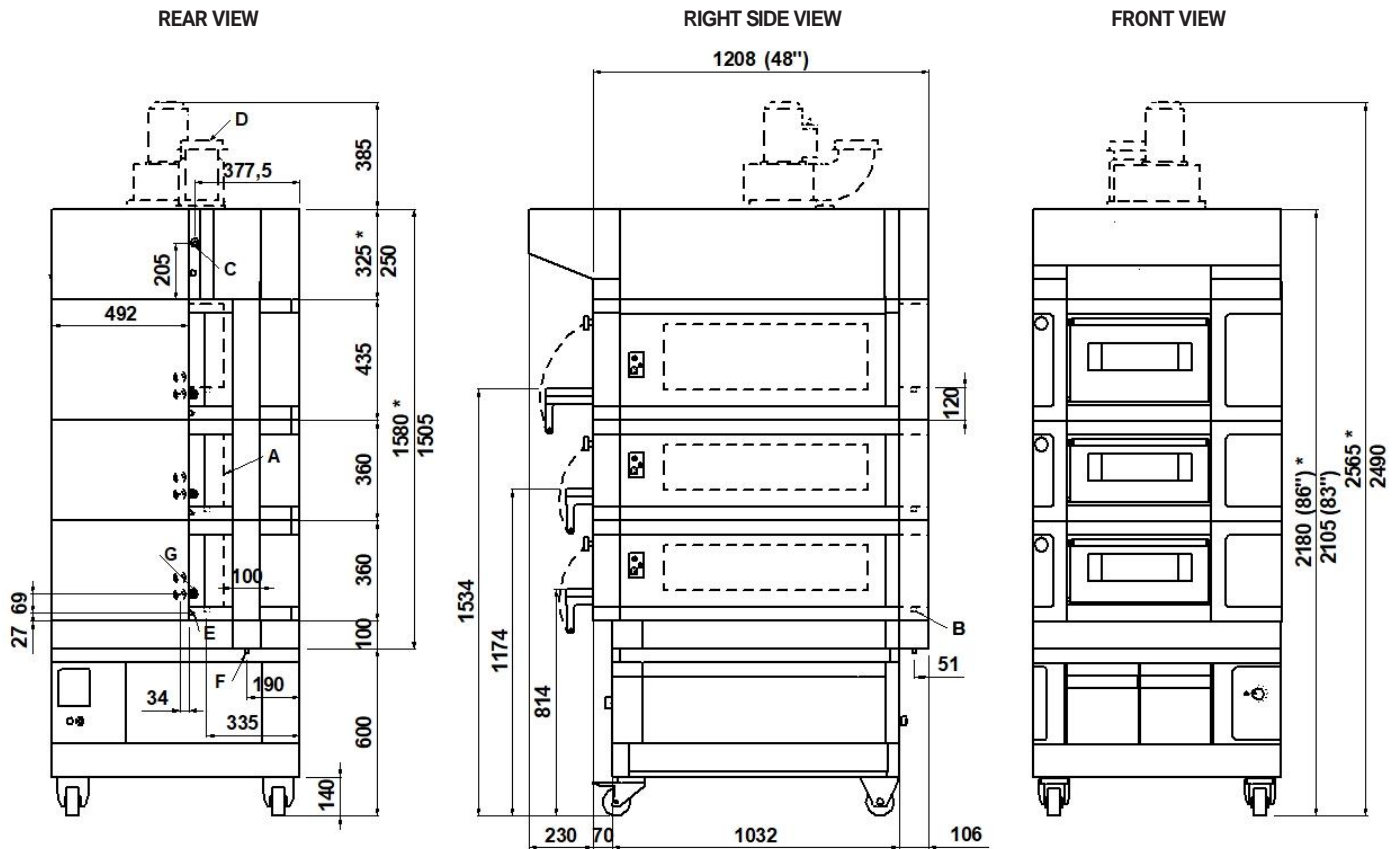

**NOTE:** The dimensions indicated in the views are in millimeters. \*Dimensions refer to the oversized hood.

<b>A</b> steamer 1200W (see data sheet)	<b>B</b> 3/4" male steamer water inlet	<b>C</b> Ø16 Hood condensate exhaust	<b>D</b> Ø150 steam exhaust
<b>E</b> M6 equipotential screws	<b>F</b> Ø12 condensate exhaust	<b>G</b> fairleads	

**DIMENSIONS**

External height	1255mm
External depth	1208mm
External width	890mm
Weight	395kg

**SHIPPING INFORMATION**

Packed in wooden crate	
Height	1800mm
Depth	1643mm
Width	1100mm
Weight	(395+70)kg

**FEEDING AND POWER**

Standard feeding	
A.C. V400 3N	
Feeding on request	
A.C. V230 3	
Frequency	50/60Hz
Max power	15,3kW
*Average power cons	4,5kWh
Connecting cable for each chamber	
type H07RN-F	
5x2,5mm <sup>2</sup> (V400 3N)	
4x4mm <sup>2</sup> (V230 3)	
Power supply (optional prover)	
A.C. V230 1N 50/60 Hz	
Max power	1.5kW
*Average power cons	0.8kWh
Conn. Cable type H07RN-F 3x1,5mm <sup>2</sup>	

**TOTAL BAKING CAPACITY**

Tray (600x400)mm	3	When combined with leavening compartment or Stand:	
Pizza diameter 300mm	6	Max height	2400mm
Pizza diameter 450mm	3	Max weight	(465+80)kg

\* This value is subject to variation according to the way in which the equipment is used  
**NOTE:** MORETTI FORNI S.P.A. reserves the right to modify the characteristics of the products illustrated in this publication without prior notice



**S50**  
TECHNICAL DATA

SHIPPING INFORMATION H16 (H15 FASTBAKE)		S50E_1_16	S50E_2_16	S50E_3_16
Packed in wooden crate	Height	860mm	1220mm	1580mm
	Icon height	960mm	1320mm	1680mm
	Weight	(160+50)kg	(270+60)kg	(380+70)kg
When combined with prover or Stand	Max. height	1860mm	2070mm	2230mm
	Max. icon height	1940mm	2150mm	2310mm
	Max. weight	(225+60)kg	(335+70)kg	(445+80)kg
SHIPPING INFORMATION H22		S50E_1_22	S50E_2_22	S50E_3_22
Packed in wooden crate	Height	950mm	1400mm	1850mm
	Icon height	1050mm	1500mm	1950mm
	Weight	(175+50)kg	(285+60)kg	(395+70)kg
When combined with prover or Stand	Max. height	1950mm	2250mm	2500mm
	Max. icon height	2030mm	2330mm	2580mm
	Max. weight	(245+60)kg	(355+70)kg	(465+80)kg
SHIPPING INFORMATION STONEBAKE		S50R_1_16	S50R_2_16	S50R_3_16
Packed in wooden crate	Height	860mm	1220mm	1580mm
	Icon height	960mm	1320mm	1680mm
	Weight	(180+50)kg	(310+60)kg	(440+70)kg
When combined with prover or Stand	Max. height	1860mm	2070mm	2230mm
	Max. icon height	1940mm	2150mm	2310mm
	Max. weight	(245+60)kg	(375+70)kg	(495+80)kg

FEEDING AND POWER (REFERRED TO 1 BAKING CHAMBER)	Max power	Multibake	kW	5,1
	*Average power consumption			kWh
	Max power	Stonebake	kW	5,1
	*Average power consumption		kWh	1,7
	Max power	Romanbake (no Fource® Technology)	kW	6
	*Average power consumption		kWh	1,8
	Max power	Steambake	kW	5,0
	*Average power consumption		kWh	1,5
	Max power	Pastrybake	kW	3,8
	*Average power consumption		kWh	1,1
	Max power	Fastbake (no Fource® Technology)	kW	6
	*Average power consumption		kWh	1,8

MAX TEMPERATURE	Multibake/Stonebake/Romanbake	°C/°F	450°C	842°F
	Steambake		350°C	662°F
	Pastrybake		270°C	518°F
	Fastbake		500°C	932°F

Max power with Fource® Technology on average -20%

Max power with Fource+® Technology (specific for bakery) on average -40%

\* This value is subject to variation according to the way in which the equipment is used  
NOTE: MORETTI FORNI S.P.A. reserves the right to modify the characteristics of the products illustrated in this publication without prior notice